

MISCELLANEOUS COURSES 2024



TABLE OF CONTENTS

Focused Approach to 2024 Course Offering . . .	3-4
Bookings & Queries Contact Details	5
Engineers' Appreciation of Welding	6-7
ASME Codes of Construction and the National Board Inspection Code	8-9
AWS D1.1 – Steel Structure	10-11
Heat Treatment Practitioner	12-13
Paint Inspector	14-15
Welding Symbols	16-17
Weld Quality Management and Welding Coordination	18-19



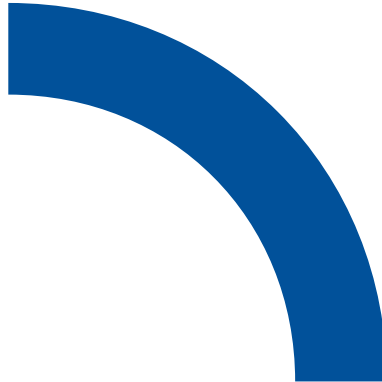

SAIW offers industry developed training programmes, which aim to provide the candidates with the necessary skills to meet industry needs. Our skills programme is in the process of being registered with the relevant QCTO, and once registered, may be recognised as part qualifications and contribute credits towards NQF aligned qualifications.

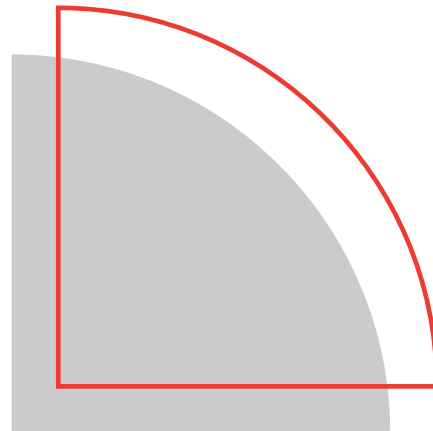

FOCUSED APPROACH TO 2024 COURSE OFFERING

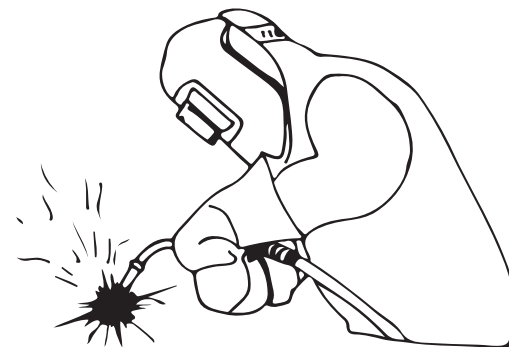

RATIONALISED NUMBER OF COURSES MEANS STUDENTS SHOULD PLAN AHEAD AND BOOK TODAY!

The aftershocks of the COVID-19 pandemic and resultant shifts in student numbers and their availability have seen the SAIW rationalise its current approach so that although the number of scheduled courses we offer remains exactly the same, but the number of times these particular courses are offered through the year has been reduced, to provide a more streamlined offering. In line with this more focused approach, we are therefore proud to launch our courses for 2024!

(SEE THE FULL LIST IN THE TABLE ON THE NEXT PAGE WHICH PROVIDES A CLEAR IDEA OF THE COURSES WE OFFER).

Cost benefit

The cost benefit of this streamline approach is that a third of our courses have been reduced in price and more than half our course prices have been increased at less than the inflation rate.

Plan ahead

The more streamlined and cost-effective approach means that students need to plan their training schedule for 2024 well in advance and book early to ensure they are in time for their desired course start date next year. *See your options on the next page.*

Non-scheduled & Regional Courses – demand dependent

Despite this streamlined approach, the SAIW remains committed to offering scheduled and non-scheduled regional courses in Cape Town and Durban. A minimum of five students are required per course to run. As soon as the minimum number of people have booked in your region, the course will be scheduled.

SAIW 2024 COURSE START DATES AT A GLANCE....

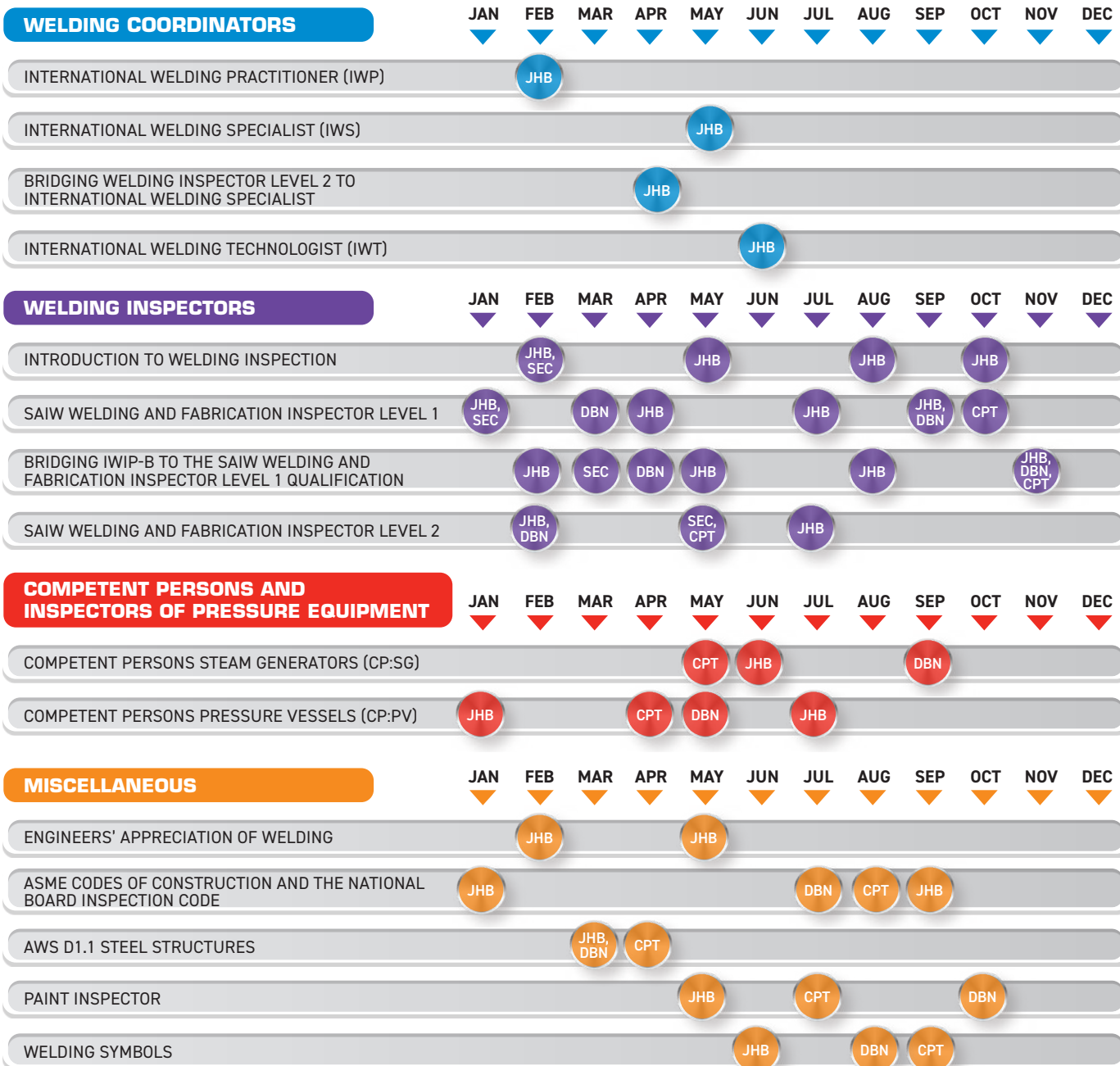

BOOKINGS & QUERIES

CONTACT DETAILS

Training	training@saiw.co.za
Practical Welding	welding@saiw.co.za
Examinations	exams@saiw.co.za
Qualification & Certification	qualcert@saiw.co.za
Company Audits	iso3834@saiw.co.za
Technical Services	technical@saiw.co.za
Laboratory Testing	mat.lab@saiw.co.za
Payments / Account	debtors@saiw.co.za
Invoicing	invoicing@saiw.co.za
Feedback	info@saiw.co.za
Complaints / Compliments	quality@saiw.co.za
Appeals	quality@saiw.co.za
Quality	quality@saiw.co.za
Formal interaction	info@saiw.co.za
Creditors	creditors@saiw.co.za

Management

Finance & Administration	michelle.warmback@saiw.co.za
Training	mark.digby@saiw.co.za
Practical Welding	confidence.lekoane@saiw.co.za
Technical Services	confidence.lekoane@saiw.co.za
Company Audit & Certification	renier.mostert@saiw.co.za
Personnel Examinations	harold.jansen@saiw.co.za
Personnel Qualification / Certification	harold.jansen@saiw.co.za
Approved Training Bodies	harold.jansen@saiw.co.za
Executive Director	john.tarboton@saiw.co.za

ENGINEERS' APPRECIATION OF WELDING



COURSE INFORMATION

ENTRY REQUIREMENTS

SAIW does not restrict access to this course but it is important to appreciate that it is primarily aimed at plant, maintenance and project engineers, engineering superintendants, engineering technicians tasked with managing the welding function and senior quality assurance personnel.

COURSE OUTLINE

- Terms and definitions related to welding
- Introduction to welding processes
- Basic metallurgy
- Welding defects
- Introduction to non-destructive testing
- Inspection and quality assurance
- Codes of manufacture

COURSE DURATION

5 days

PRICING (Including VAT)

Corporate Member	R 16,600
Non-Corporate Member	R 17,900

PLEASE NOTE

The Appreciation of Welding course is designed to provide personnel with an overview of welding technology in order to understand welding better and make informed welding related decisions.

ENGINEERS' APPRECIATION OF WELDING

In many companies a mechanical or electrical engineer, engineering superintendent or engineering supervisor is given the responsibility of managing 'the welding department'. Often this engineer will have absolutely no welding background and almost certainly his/her university or college study programme will have included no training in welding technology. If the engineer is lucky he/she may be assisted by an experienced welder or even a welding supervisor but this is not enough to accept the responsibilities assigned to his/her job.

For these reasons the course is one of the Institute's oldest courses and one of its most successful. The course was first developed in the early 1980s when it was derived from an in-company training course. It has been continuously updated to ensure industry relevance. Many engineers from all types of large companies and parastatals have attended the course as part of their professional development. It is, however, an extremely important course for engineers working in smaller companies where there is very little in-house back-up for the engineer who has to be a jack-of-all-trades.

The course introduces engineers to the complexities of welding, informing them of what can go wrong and the consequences of a failure including economic disaster. It covers the common welding processes and their applications. It describes the effect of welding on materials and welding defects and their causes. It looks at cost issues, the need for qualified welding procedures and how to go about specifying them. Importantly engineers are encouraged to bring their welding experiences and problems to the course for sharing with the class in discussion. The case history discussion period is held at the end of the course and is often one of the most helpful parts of the course for the engineer. It's very much about helping the engineer to know and be aware of when he/she needs to bring in specialist help.

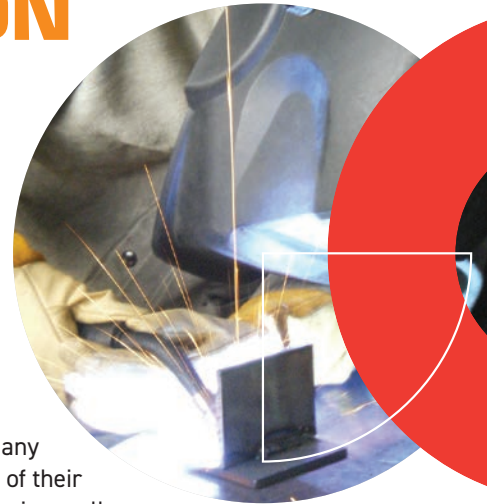

The course can be held in-company and anyone interested in running the course can contact Confidence Lekoane on confidence.lekoane@saiw.co.za.



CPD credits available for this course

COURSE SCHEDULE | **Engineers' Appreciation of Welding**

JOHANNESBURG

WEEK	COURSE INFORMATION	HRS	JHB 01	JHB 02
1	Overview of Welding Technology	40	19 - 23 Feb	06 - 10 May

www.saiw.co.za

Please refer to contacts on page 5

ASME CODES OF CONSTRUCTION AND THE NATIONAL BOARD INSPECTION CODE

COURSE INFORMATION

ENTRY REQUIREMENTS

- 1 There are no specific entry requirements for engineering personnel attending the course
- 2 Welding fabrication inspectors should preferably attain the SAIW Level 2 qualification before attending this course

THE COURSE IS INTENDED FOR

Welding fabrication inspectors, engineers, technologists, technicians and supervisors who wish to improve their knowledge of these codes.

COURSE OUTLINE

The course content covers:

- ASME Section I
- ASME Section VIII Division I
- ASME Section IX
- National Board Inspection Code

COURSE DURATION

10 days

PRICING (Including VAT)

Corporate Member	R 29,400
Non-Corporate Member	R 31,800



ASME CODES OF CONSTRUCTION AND THE NATIONAL BOARD INSPECTION CODE

This ASME Codes of Construction course is ideal for welding inspectors involved in boiler and/or pressure vessel fabrication, repair or modification. The course is mandatory for inspectors aiming for certification as an Inspector of Pressure Equipment (IPE) with the intention of working for an Approved Inspection Authority (AIA).

The syllabus includes requirements for welding, fabrication and inspection: design of vessels and boilers; allowable materials; strength calculations for openings; qualification of welders and welding procedures; inspection and tests; marking and reports; pressure relief devices; duties of

inspectors; using the codes and calculations. NBIC is used for post construction activities in the installation, inspection, repair and alteration of pressure retaining equipment.

The course is suitable for project and maintenance engineers and engineering supervisors with responsibility for boilers and pressure vessels and as an introduction to the ASME Code.

Candidates should have a Grade 10 qualification as a minimum. Candidates should preferably have completed the SAIW level 2 welding inspector qualification prior to doing this course, which is a requirement for IPE certification.

THE COURSE ADDRESSES THE REQUIREMENTS OF:

1 ASME Section 1 – Rules of Construction for Power Boilers.

2 ASME Section VIII Division 1 – Rules of Construction for Pressure Vessels.

3 ASME Section IX – welding and brazing qualifications and NBIC – National Board Inspection Code.

Successful graduates will have an appreciation for the code requirements and be able to use the codes and interpret and apply the fabrication and inspection requirements in their daily work activities.

The course is specifically designed to introduce students on the use of relevant code sections in a logical and methodical manner.

COURSE SCHEDULE | ASME Codes of Construction

JOHANNESBURG, DURBAN, CAPE TOWN

WEEK	COURSE INFORMATION	HRS	JHB 01	JHB 02	DBN 01	CPT 01
1	ASME Section VIII and NBIC	32	29 Jan - 01 Feb	30 Sep - 03 Oct	15 - 18 Jul	26 - 29 Aug
2	ASME Section I and Section IX	32	05 - 08 Feb	07 - 10 Oct	22 - 25 Jul	02 - 05 Sep
	Examination - ASME Section VIII and NBIC	4	02 Feb	04 Oct	19 Jul	30 Aug
	Examination - ASME Section I and Section IX	4	09 Feb	11 Oct	26 Jul	06 Sep

AWS D1.1 - STEEL STRUCTURE

COURSE INFORMATION

ENTRY REQUIREMENTS

Personnel involved in the fabrication of steel structures including inspection, quality control and fabrication should attend this course. Engineering personnel wishing to improve their understanding of inspection and quality control during fabrication of steel structures are also encouraged to attend this course.

COURSE OUTLINE

This course provides an understanding of this welding fabrication code and covers the following aspects of the 2015 version of the code:

- Section 1 - General requirements related to welded steel structures
- Section 3 - Pre-qualified welding procedures
- Section 4 - Welding procedure and performance qualification
- Section 5 - Fabrication requirements
- Section 6 - Inspection requirements
- Practical exercises in the use of the code

COURSE DURATION

3 days

PRICING (Including VAT)

Corporate Member	R 10,400
Non-Corporate Member	R 11,300

AWS D1.1 – STEEL STRUCTURE

AWS D1.1 code is widely used both locally and internationally for managing welding quality in structural steel constructions and buildings, bridges, draglines, oil production platforms, mining headgear, shaft steelwork, earthmoving and mining equipment, as well as power station structures.



SUCCESSFUL CANDIDATES WILL BE ABLE TO USE AND INTERPRET THE CODE WITH REGARDS TO:

1 Pre-qualified welding procedures

2 Qualification of welders and welding procedures

3 Allowable materials

4 Fabrication requirements

5 Inspection and tests

6 Marking and reports

The course is intended to focus on the fabrication and inspection requirements of the code. It is not intended to cover design aspects.

COURSE SCHEDULE | AWS D1.1 – Steel Structures

JOHANNESBURG, DURBAN, CAPE TOWN

WEEK	COURSE INFORMATION	HRS	JHB 01	DBN 01	CPT 01
1	AWS D1.1 – Steel Structure	24	18 - 20 Mar	25 - 27 Mar	02 - 04 Apr



CPD credits available for this course

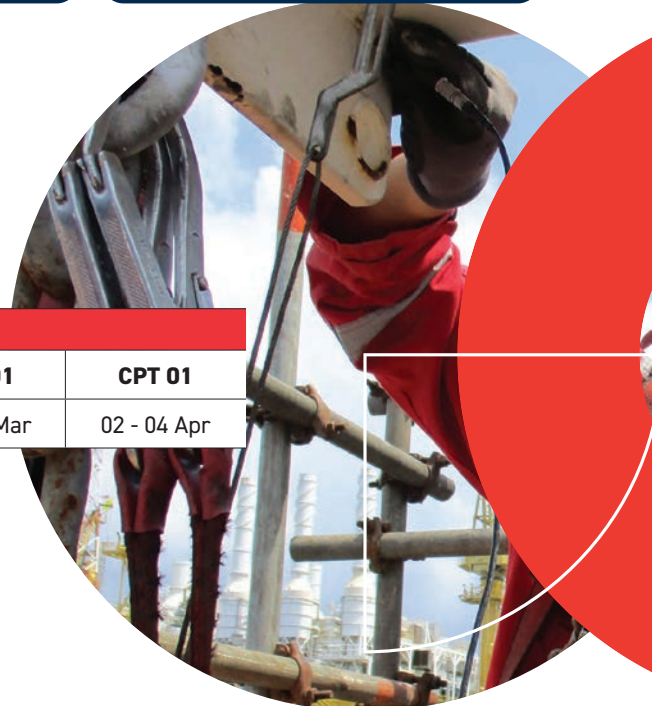

HEAT TREATMENT PRACTITIONER

COURSE INFORMATION

Covers heat treatment requirements for the fabrication of pressure vessels, steam generators and process equipment.

THE FOLLOWING FABRICATION CODES ARE DEALT WITH IN THIS COURSE:

ASME VIII

- BS2633
- EN13445
- EN13480
- AWS D1.1

COURSE DURATION

3 days

PRICING (Including VAT)

Corporate Member **R 29,400**

Non-Corporate Member **R 31,800**

SUCCESSFUL CANDIDATES WILL

1 understand the necessity to perform pre- and post-weld heat treatments

2 be able to determine heat treatment cycles in accordance with various codes

3 be able to set up and operate heat treatment equipment

HEAT TREATMENT PRACTITIONER

Heat Treatment Practitioner performing local heat treatment of welded fabrications on site, or in a workshop, using resistance heating, will benefit from this course. The course is also suitable for maintenance personnel who are responsible for supervising heat treatment operations. Candidates who preferably have a Grade 10 qualification as well as experience in engineering and/or metal working is recommended.

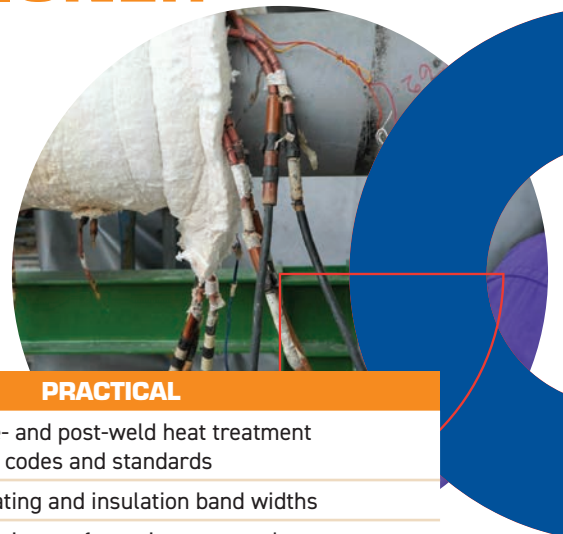

COURSE CONTENT

THEORY	
1	Basic metallurgy
2	Heat treatment definitions
3	Welding processes
4	Welding effects on materials – why is heat treatment necessary?
5	Heat treatment cycles, heating and cooling rates, soaking temperatures, soaking times
6	Code and material specification requirements for welding
7	Pre-heat, post-weld heat treatment, normalising, annealing, hydrogen removal
8	Methods of heat treatment
9	Equipment

PRACTICAL	
1	Determining pre- and post-weld heat treatment requirements to codes and standards
2	Determining heating and insulation band widths
3	Determining heating configurations on nozzles
4	Setting up equipment for weld heat treatments – thermocouples, heaters, insulation
5	Operating heat treatment equipment

For the below courses, book by emailing info@saiw.co.za. As soon as the minimum number of people have been booked in your region, the course will be scheduled.

COURSE SCHEDULE | Heat Treatment Practitioner

JOHANNESBURG, DURBAN, CAPE TOWN					
WEEK	COURSE INFORMATION	HRS	JHB 01	DBN 01	CPT 01
1	Welding Processes	40	*	*	*
	Materials				
2	Post Weld Heat Treatment Codes	40	*	*	*
	Examination - Paper A	3	*	*	*
	Examination - Paper B	3	*	*	*

* Contact elizabeth.shole@saiw.co.za who will put you on the waiting list. As soon as there are five prospective students, a course will be scheduled.

PAINT INSPECTOR

COURSE INFORMATION

COURSE DURATION

4 days and 1 day examination

PRICING (Including VAT)

Corporate Member **R 16,600**

Non-Corporate Member **R 17,900**



Scan this QR code to download the SAIW Course Prospectus App onto your cellular phone.

PAINT INSPECTOR

The Paint Inspectors (PI) course provides candidates with the basic knowledge regarding surface preparation and paint application to ensure engineering materials are suitably protected from environmental decay and/or corrosion, through the use of protective coatings.

Furthermore, the practical content of the course enables the candidate not only to assess the application process and newly applied protective layers, but also to identify coating damage on established installations.

Candidates who are involved in the surface preparation, paint application or corrosion protection industries, who want to further their career opportunities in the supervisory or coating evaluation facets of corrosion protection of engineering materials, may apply.



COURSE CONTENT

THEORY

- 1 Principles of corrosion
- 2 Corrosion protection
- 3 Selection of coating systems
- 4 Surface preparation methods and applicable standards
- 5 Paint constituents
- 6 Application methods and applicable standards
- 7 Paint specifications and datasheets
- 8 Measurement and evaluation techniques and processes
- 9 Site and shop applications
- 10 Coating defects and failures
- 11 Definitions of coating related terms

PRACTICAL

- 1 Assessment of environmental conditions relating to coating application
- 2 Perform inspections on newly prepared substrates
- 3 Evaluate newly coated surfaces
- 4 Test various aspects of an established coating system and identify typical coating damage and failures

These results and instructions are consequently used to generate suitable report sheets.

COURSE SCHEDULE | Paint Inspector

JOHANNESBURG, DURBAN, CAPE TOWN

WEEK	COURSE INFORMATION	HRS	JHB 01	DBN 01	CPT 01
1	Theory and Practical	32	20 - 23 May	28 - 31 Oct	15 - 18 Jul
	Examination - Multiple Choice	1	24 May	01 Nov	19 Jul
	Examination - Narrative	2			
	Examination - Practical	2			



Scan this QR code to download the SAIW Course Prospectus App onto your cellular phone.

WELDING SYMBOLS

COURSE INFORMATION

COURSE DURATION

1 day

PRICING (Including VAT)

Corporate Member **R 3,600**

Non-Corporate Member **R 3,900**

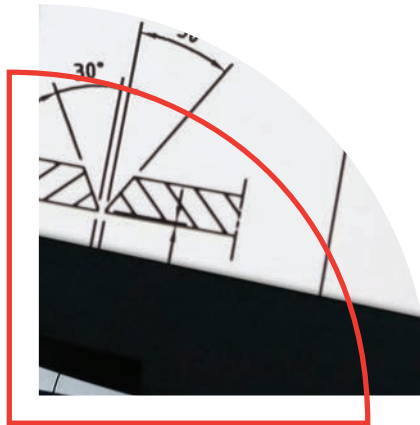

Scan this QR code to download the SAIW Course Prospectus App onto your cellular phone.

WELDING SYMBOLS

Welding symbols are used as a pictorial language to convey weld requirements. The weld symbol conveys to the fabricator the position of welds, type of joint to be used, the size of the weld and the amount of weld metal to be deposited.

Welders that work with fabrication drawings must be able to interpret welding symbols to prepare the joint and apply a weld that meets the specifications. Welding inspectors must be able to read and interpret welding plans.

The welding symbol course provides a detailed review of the use of welding symbols in the fabrication environment.

The course covers the use of the European system for welding symbols (ISO 2553) as well as the use of the American system (AWS A2.4).

The course will also deal with the difficulties encountered in engineering design and fabrication workshops with the use of two different systems. Concepts covered in the course include, joint types and weld types, basic joint geometry, key terms, and basic rules of welding symbols and non-destructive testing symbols.

The course covers all types of welds including groove welds, fillet welds, plug and slot welds, spot and projection welds, and stud, seam, surfacing, and edge welds.

This course is ideal for all fabrication personnel including welding supervisors, quality controllers and welding inspectors. The course is also ideal for personnel involved in engineering design as well as draughting and detailing personnel.

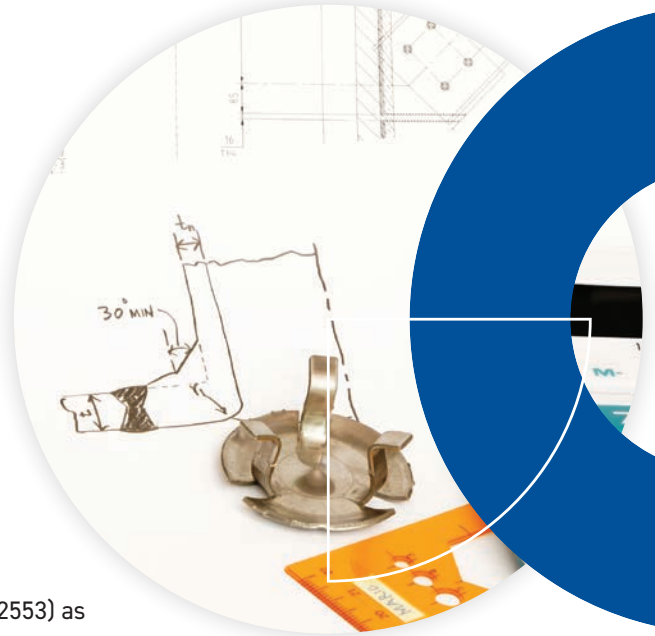

COURSE SCHEDULE | Welding Symbols

JOHANNESBURG | DURBAN | CAPE TOWN

JHB 01	DBN 01	CPT 01
18 Jun	05 Aug	25 Sep



CPD credits available
for this course

WELD QUALITY MANAGEMENT AND WELDING COORDINATION

ISO 3834 and ISO 14731

COURSE INFORMATION

COURSE DURATION

1 day

PRICING (Including VAT)

Corporate Member **R 3,600**

Non-Corporate Member **R 3,900**



Scan this QR code to download the SAIW Course Prospectus App onto your cellular phone.

WELD QUALITY MANAGEMENT AND WELDING COORDINATION

Manufacturing processes such as fusion welding are widely used to produce many products, and for some companies, these are the key production features.

Products may range from simple to complex. Examples include pressure vessels, domestic and agricultural equipment, cranes, bridges, transport vehicles and other items. These processes exert a profound influence on the cost of manufacture and on the quality of the product.

It is therefore important to ensure that these processes are carried out in the most effective way and that appropriate control is exercised over all aspects of the operation.

The ISO 3834 Quality Management System will be consulted to clearly define all the welding related aspects and how to manage them on a day to day basis.

The course is aimed at assisting those in the Welding Coordination teams to implement and manage ISO 3834 as well as to familiarise them with their roles as stated in the ISO 14731 Standard.



COURSE SCHEDULE | Weld Quality Management and Welding Coordination

JOHANNESBURG, DURBAN, CAPE TOWN

WEEK	COURSE INFORMATION	HRS	JHB 01	DBN 01	CPT 01
1	ISO 3834 and ISO 14731	8	*	*	*

No exam. You will receive a certificate of attendance.

* Contact elizabeth.shole@saiw.co.za who will put you on the waiting list. As soon as there are five prospective students, a course will be scheduled.

SAIW / ISO 3834 certification is vital for successful mining.

By using SAIW / IIW ISO 3834 certified suppliers for your mining operations,
you'll ensure the quality of welded fabrications improve safety on the mine
and minimize costly downtime as well.

Since 2008, the Southern African Institute of Welding (SAIW)
in association with the leading global authority on welding
The International Institute of Welding (IIW) has been ensuring
and verifying compliance with international ISO 3834 standards.

SAIW / IIW ISO 3834
Certification is good
for mining.



SAIW
Certification





www.saiw.co.za

Please refer to contacts on page 5







JOHANNESBURG (HEAD OFFICE)

GPS co-ordinates: 26°12'39.6"S 28°01'35.8"E
Southern African Institute of Welding NPC.
52 Western Boulevard, off Main Reef Road,
City West, Johannesburg
P O Box 527, Crown Mines, 2025

Tel: +27 (0)11 298 2100

Email: info@saiw.co.za

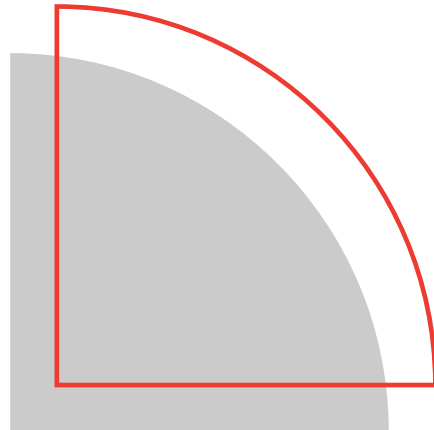
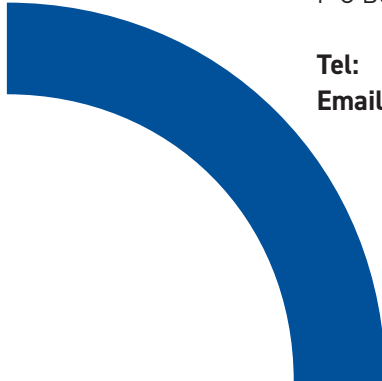
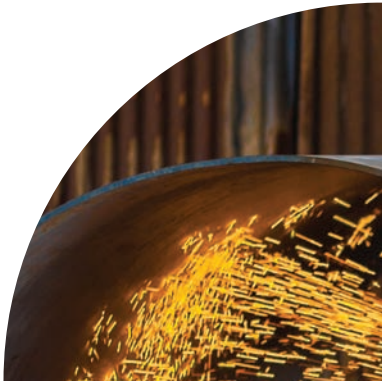

FOLLOW SAIW ON



www.saiw.co.za

